

## INSTALLATION GUIDE-PENDANT

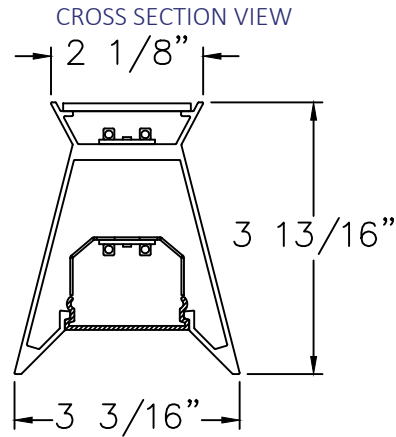

Risk of fire and electrical shock. In accordance with national local building and electrical codes, CORONET lighting fixtures must be installed by a qualified electrician. Disconnect power at electrical panel before servicing.



### PART LIST

- A-End Plate
- B-Male Gripper
- C-Extrusion
- D-Canopy
- E-Octagonal Junction Box
- F-Aircraft Cable
- G-Power Feed Cable
- H-Bushing

### ISOMETRIC VIEW

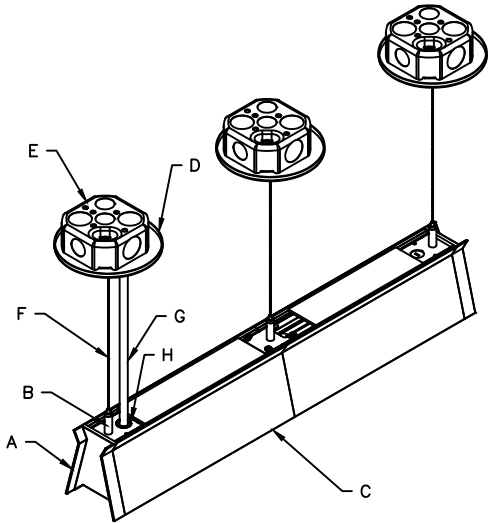

### SIDE VIEW

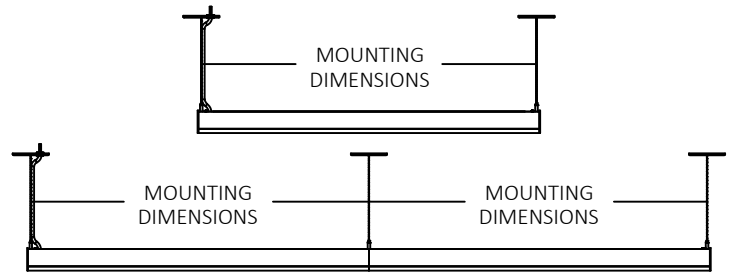

PLEASE CONSULT FACTORY SHOP DRAWINGS FOR SUSPENSION POINTS.

### REMOTE DRIVER DISTANCES

WIRE GAUGE	12	14	16	18
MAX. DISTANCE	100 ft	80 ft	50 ft	35 ft

### FEED DETAIL

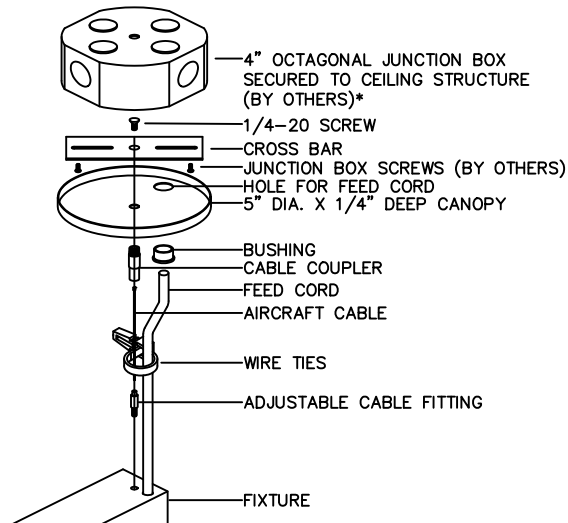

### NON FEED DETAIL

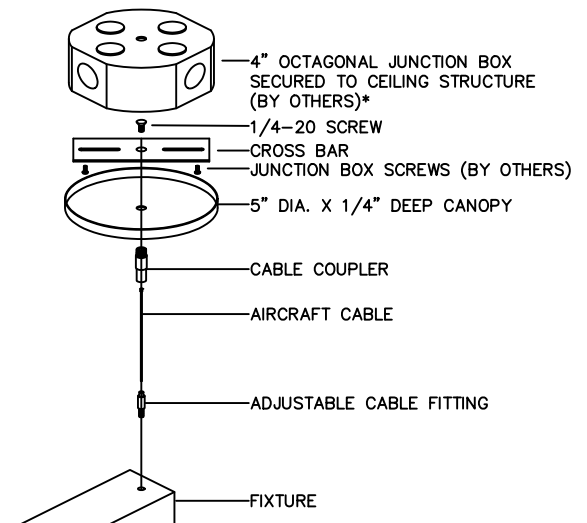

\*NOTE: JUNCTION BOXES MUST BE SECURELY FIXED TO THE CEILING AND ATTACHED TO THE STRUCTURAL MEMBER INSIDE THE CEILING BEFORE PROCEEDING WITH INSTALLATION.

INSTALLATION GUIDE-PENDANT



Risk of fire and electrical shock. In accordance with national local building and electrical codes, CORONET lighting fixtures must be installed by a qualified electrician. Disconnect power at electrical panel before servicing.

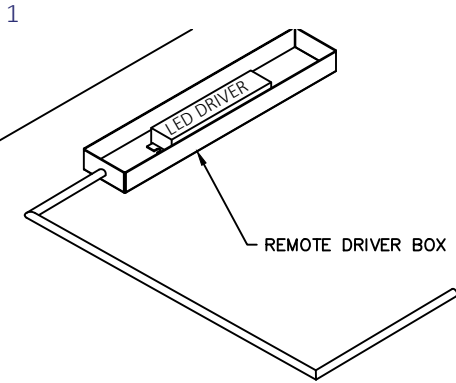

If you have a remote driver, install it in the ceiling and run conduit to the fixture. Refer to the remote driver box on page 1 for acceptable lengths of cable. Note: Use whip or plenum cable (both by others) from the junction box to the remote box. If you have an integral driver, skip to step 3.

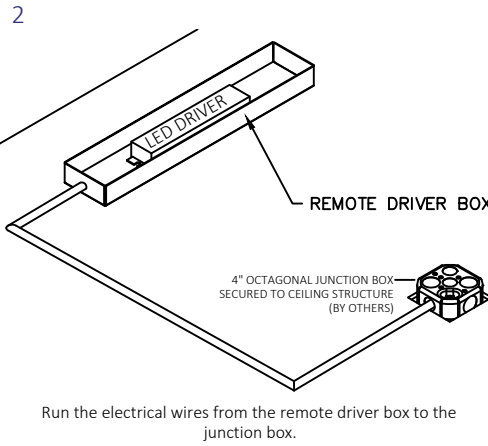

Run the electrical wires from the remote driver box to the junction box.

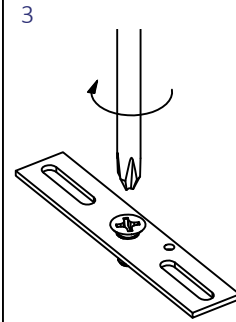

Screw the provided 1/4-20 hanging screw before attaching the cross bar to the junction box.

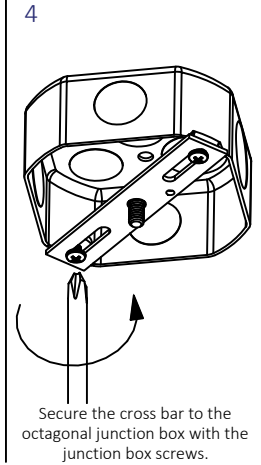

Secure the cross bar to the octagonal junction box with the junction box screws.

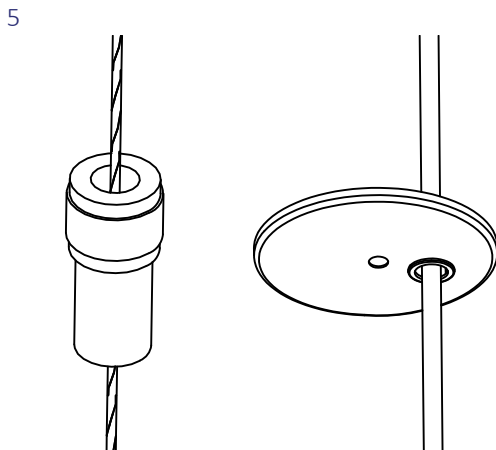

Run the aircraft cable through the cable coupler and the power feed cable through the canopy respectively.

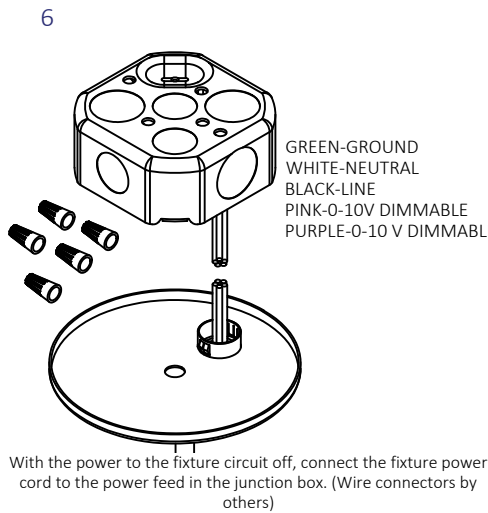

With the power to the fixture circuit off, connect the fixture power cord to the power feed in the junction box. (Wire connectors by others)

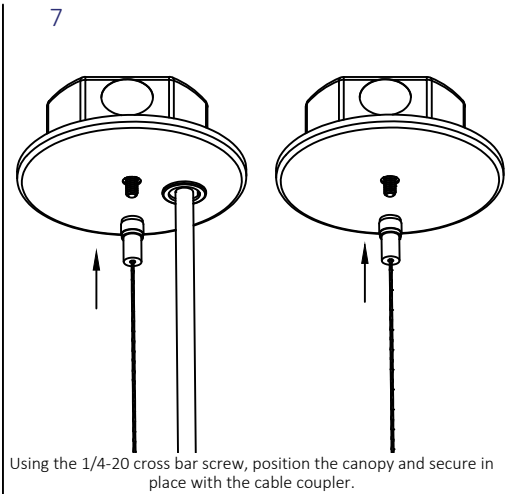

Using the 1/4-20 cross bar screw, position the canopy and secure in place with the cable coupler.

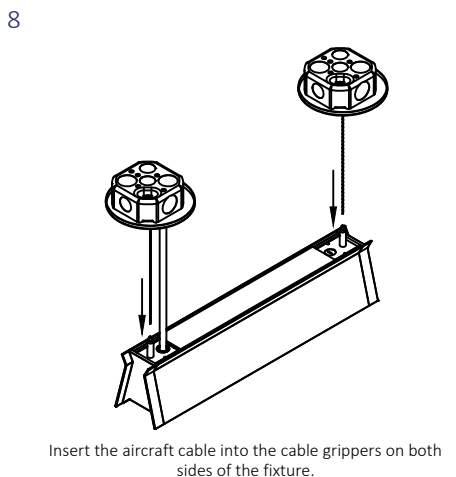

Insert the aircraft cable into the cable grippers on both sides of the fixture.

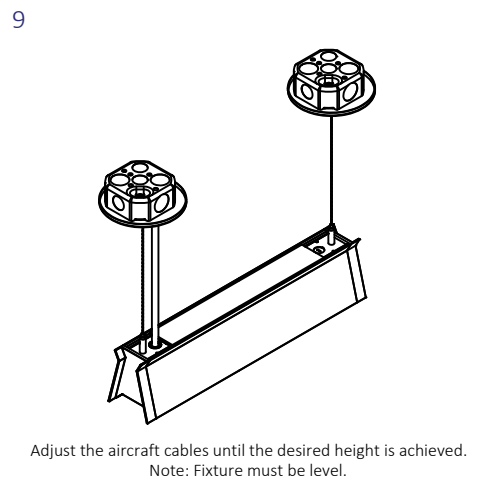

Adjust the aircraft cables until the desired height is achieved. Note: Fixture must be level.

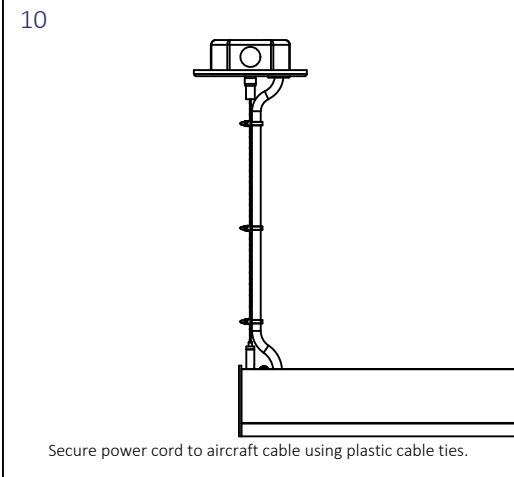

Secure power cord to aircraft cable using plastic cable ties.

NOTE: JUNCTION BOXES MUST BE SECURELY FIXED TO THE CEILING AND ATTACHED TO THE STRUCTURAL MEMBER INSIDE THE CEILING BEFORE PROCEEDING WITH INSTALLATION.

INSTALLATION GUIDE-PENDANT



Risk of fire and electrical shock. In accordance with national local building and electrical codes, CORONET lighting fixtures must be installed by a qualified electrician. Disconnect power at electrical panel before servicing.

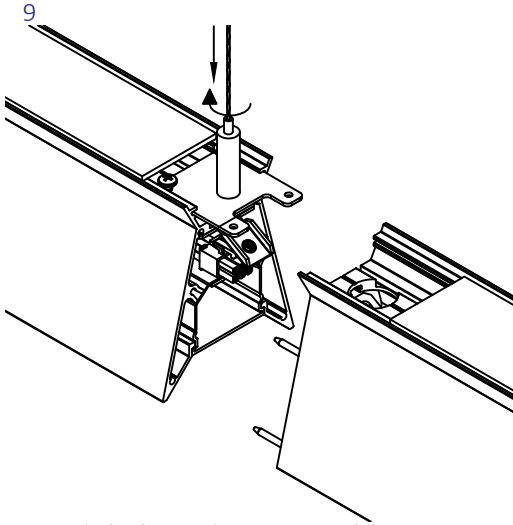

9 Mount the first fixture in the continuous run, following steps 1-8. Slide back the middle support bracket and screw on the cable gripper. If you have an UP/DN fixture, you may have to remove the top lens as well to perform the next steps.

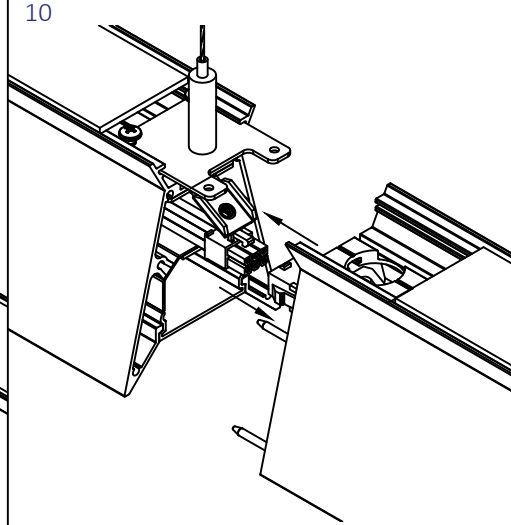

10 Before connecting the two fixtures, connect the wiring harness.

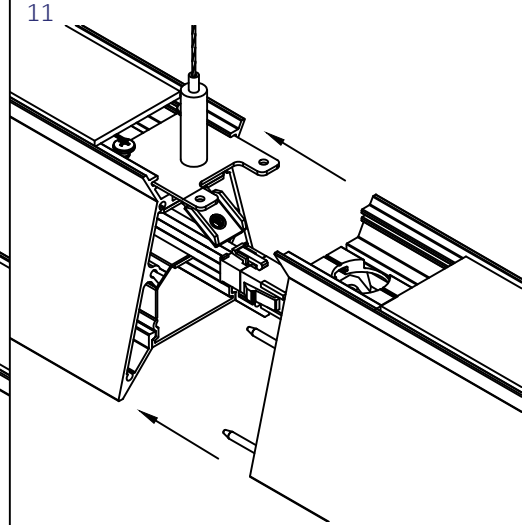

11 Align the two fixtures using the alignment pins and brackets. Warning: Keep hands clear of connection.

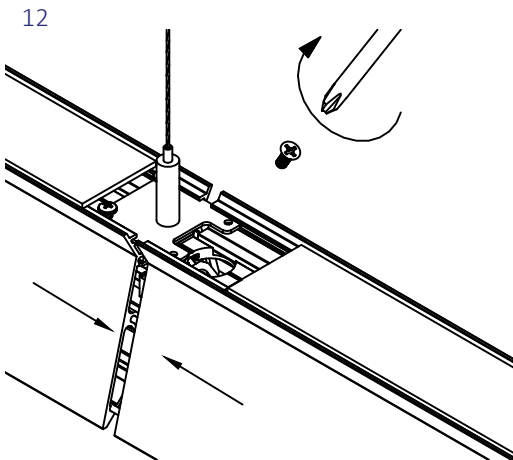

12 Use the provided 1/4-20 flat head screw to secure the connecting brackets. As you screw it in, the fixture will securely connect together. Tighten the connecting bracket screws again if needed.

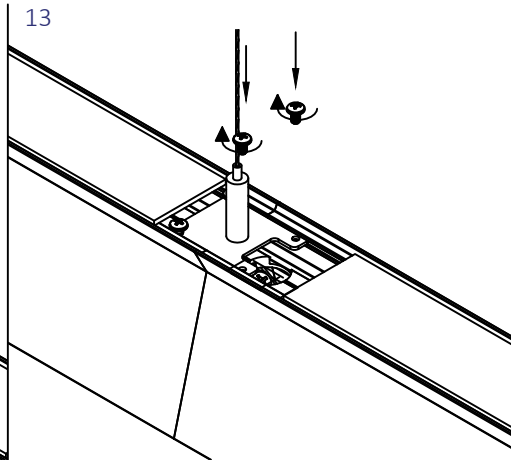

13 Use appropriate hardware to secure the middle suspension bracket in place. Reinstall the top lens as well if necessary.

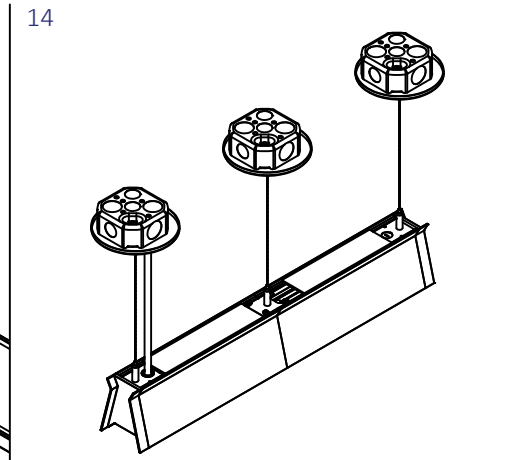

14 Fixture must be hung level at the desired height. If fixture is not level, light leaks may occur at the seam.

**GENERAL INSTALLATION CONSIDERATIONS** - See submittal drawings for job specific data.

Operating Temperature.....	-40°C to 50°C
Operating Voltage.....	110VAC-277VAC, 50Hz-60Hz
Weight.....	2-3 lbs/ft depending on configuration
Dimensions.....	See submittal drawings

- Installation by a certified electrician only. If you don't understand the instructions, don't install the fixture and please contact us for assistance.
- Read and understand the installation instructions before attempting to install or use the fixture.
- Only use fixtures with voltage for which it is rated. Do not exceed the specified voltage and current input.
- Do not use the fixture if the housing, lens, or power cable is damaged.
- Ensure that the main power supply is off before installing or wiring the fixture.
- Method of wire connection to be determined by local electrical codes and regulations.
- The external flexible cable of this luminaire cannot be field replaced; if the cord is damaged, contact Coronet.
- The light source contained in this luminaire shall only be replaced by the lighting manufacturer or his service agent or a similar qualified person.

Please contact our technical support team for assistance.

NOTE: JUNCTION BOXES MUST BE SOLIDLY FIXED TO THE CEILING AND ATTACHED TO THE STRUCTURAL MEMBER INSIDE THE CEILING BEFORE PROCEEDING WITH INSTALLATION.