

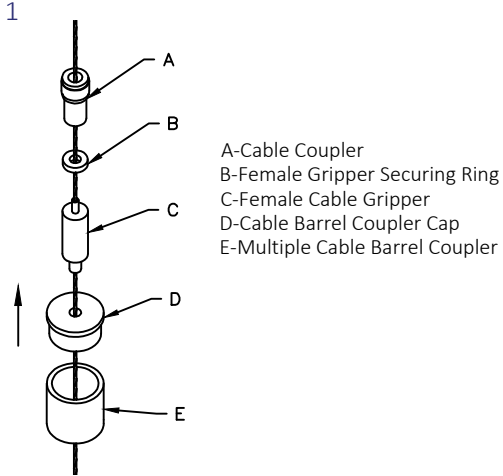

Risk of fire and electrical shock. In accordance with national local building and electrical codes, CORONET lighting fixtures must be installed by a qualified electrician. Disconnect power at electrical panel before servicing.

**NOTE:** To see the steps on how to finish installing the PRD or RING, please refer to their respective installation guides along with this one.



With the aircraft cable run through the cable gripper, run the rest of the components through the aircraft cable in the order as shown.

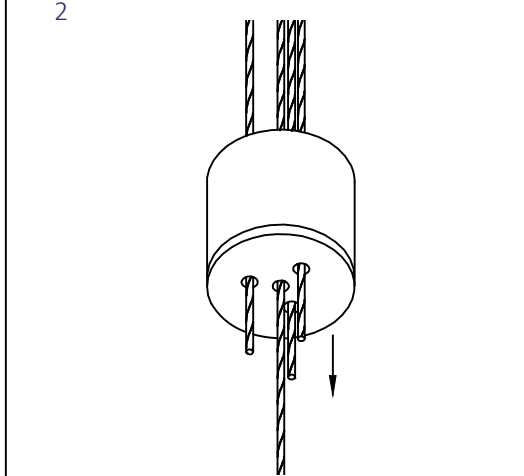

Run the three separate aircraft cables through the cable barrel coupler. NOTE: The coupler for the Ring has three holes while the splitter for the PRD has four holes.

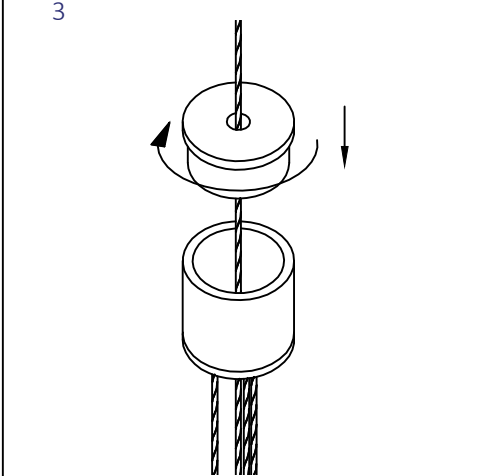

With the three aircraft cables in the coupler, secure the cap to the top of it.

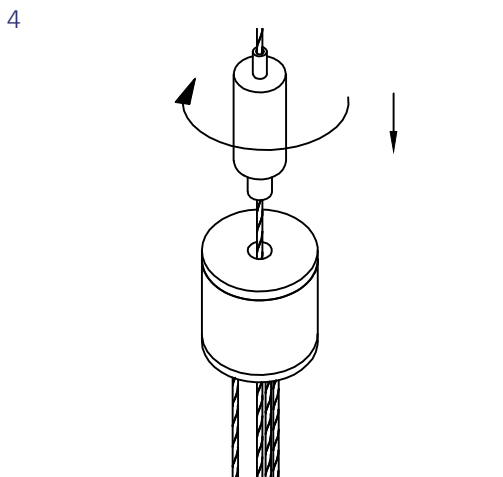

Screw the female gripper into the top of the cap to secure it in place.

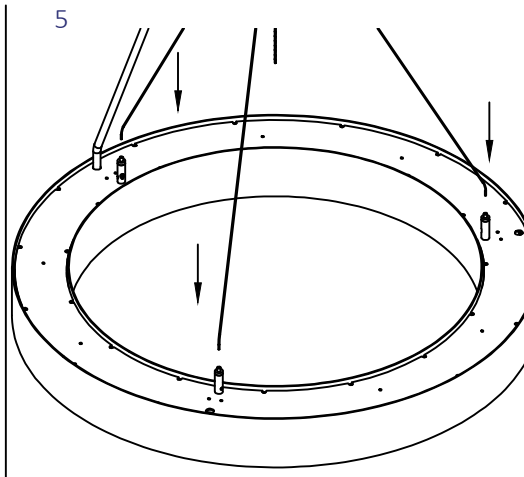

Insert the aircraft cables into all the cable grippers on the fixture.

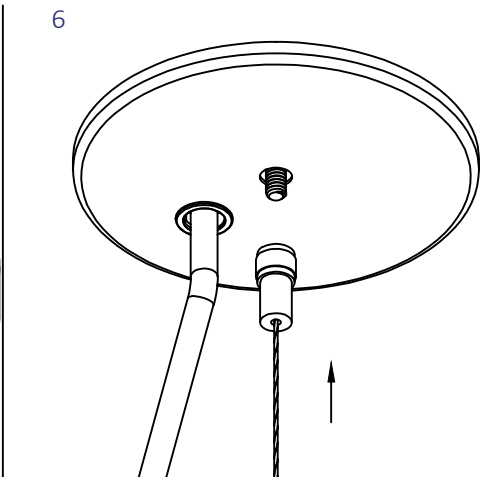

Raise the fixture up and secure it to the canopy by screwing the cable coupler to the 1/4-20 cross bar screw.

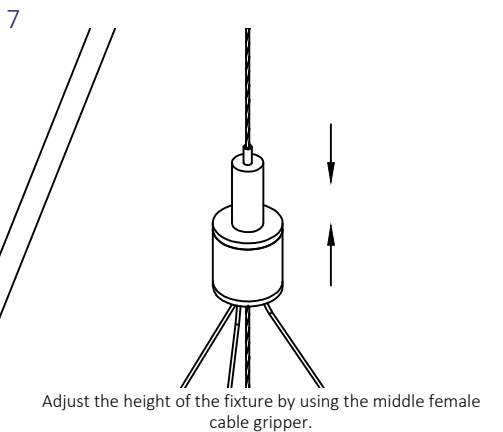

Adjust the height of the fixture by using the middle female cable gripper.

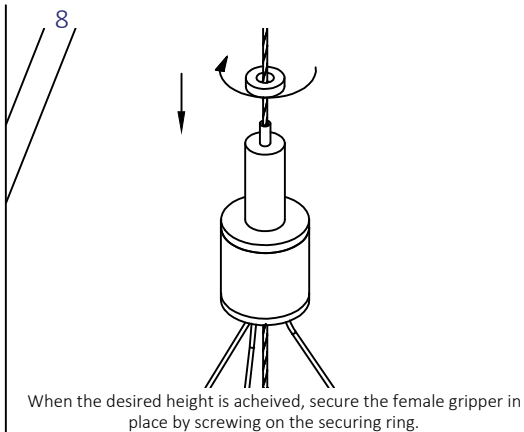

When the desired height is achieved, secure the female gripper in place by screwing on the securing ring.

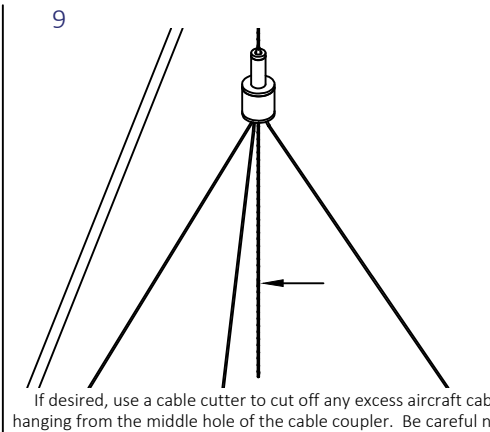

If desired, use a cable cutter to cut off any excess aircraft cable hanging from the middle hole of the cable coupler. Be careful not to cut one of the three/four suspension cables to the fixture.

\*NOTE: JUNCTION BOXES MUST BE SOLIDLY FIXED TO THE CEILING AND ATTACHED TO THE STRUCTURAL MEMBER INSIDE THE CEILING BEFORE PROCEEDING WITH INSTALLATION.